

## SP-40HA 40 Quart Mixer



### Standard Feature

- Powerful 1.5 HP custom built motor
- Three fixed speeds
- High torque transmission
- Heat-treated hardened steel alloy gears and shafts
- Permanently lubricated transmission
- Thermal overload protection
- Rigid cast iron body
- Stainless steel bowl guard with built in ingredient chute
- NSF approved enamel gray paint (optional)
- Front mounted controls
- 15 minute timer
- Industry standard #12 attachment hub
- Safety interlocked bowl guard and bowl lift
- Non-slip rubber feet
- 6 foot cord and ground plug (single phase only)

### Standard Accessories

- 40 quart stainless steel bowl
- Flat beater (aluminum)
- Stainless steel wire whip
- Spiral dough hook (aluminum)

### SPECIFICATION

#### Motor :

1.5 HP (1200W), grease packed ball bearing, air-cooled, 230V/50Hz/IPh, 220V/380V/3Ph

#### Controls :

Spar Mixer controls are front-mounted to give easy access in cramped kitchen environments. The following controls are standard on all Spar Mixers: separate start and emergency stop buttons so operators can shut down the mixer immediately in an emergency situation, a 15-minute timer which shuts off the machine after set time has elapsed, and thermal overload protection

#### Cord and Plug :

Both single phase and three phase are hard wired

#### Transmission :

Heat-treated, hardened alloy, precision milled gears operate with planetary action. Gears are packed in a long-lasting, high pressure grease. Planetary gears are driven by an oversized cog-wheel, which is in turn driven by a cogged belt powered by the motor drive shaft. Cogged belt is a long-lasting, rugged fibre/rubber composite. This unique design yields high-torque mixing power while avoiding the high cost encountered repairing direct-drive transmission components.

#### Speed :

Speed	Agitator rpm	Hub rpm's
Low Speed	99	41
Intermediate Speed	176	73
High Speed	320	113

#### Bowls and Agitators :

Standard equipment includes a 40Qt. (40L) high quality stainless steel bowl, dough hook, flat beater, and whip. A sturdy hand lever on the body column raises and lowers the bowl as well as locking in place at the top and bottom positions.

#### Attachments :

- Vegetable Slicer for #12 hub
- Meat grinder for #12 hub
- 20 quart adapter kit
- Flat beater (Stainless Steel)

#### Finish :

Top (transmission cover) :  
metallic bronze epoxy enamel  
Bottom : metallic gray epoxy enamel

#### Shipping Information :

N.W. 250kgs  
G.W. 290kgs

#### Carton Size :

Depth x Width x Height  
75cm x 65cm x 131 cm

Cartons are affixed to an undersized skid (pallet), the weight and dimensions of this skid are not included above and may vary from shipment to shipment.

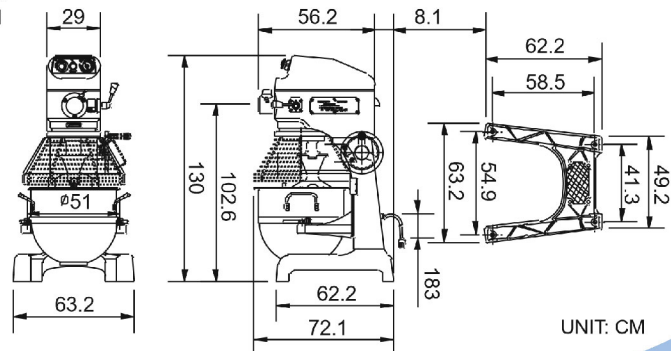

UNIT: CM

